



**BUILDING  
DEPARTMENT  
TIP SHEET**

**PERMITS: WHEN REQUIRED**

2009 IRC

**PERMITS**

No building or electrical, mechanical, or plumbing system shall be constructed, enlarged, altered, repaired, moved, demolished, or changed unless a permit has been obtained. Building, electrical, mechanical, plumbing, tree and grading permits may be required.

**PERMITS REQUIRED (Building or other)**  
(Common examples include but are not limited to the following)

1. Carports.
2. Decks more than 30" above grade.
3. Dock repairs and additions.
4. Exterior doors, windows and skylights that require a new opening.
5. Electrical circuits and service.
6. Fireplaces, wood-burning stoves, and inserts.
7. Garage conversions.
8. Home-business conversions.
9. Interior remodels.
10. Mother-in-law apartments.
11. Furnaces.
12. Water heaters.
13. New hose bibs or drinking fountains.
14. Irrigation systems.
15. Gas piping.
16. Rockeries and restraining walls over 4' in height.
17. In-ground or above ground swimming pools and swim spas 2' deep, or above ground prefabricated pools over 5,000 gallons.
18. Tree and vegetation removal, soil removal or additions (contact your jurisdiction for details)
19. Spas and saunas.
20. Residential re-roof overlay (Bothell and Kenmore only).
21. Re-roof involving structural elements, including but not limited to sheathing, skylights, change of roof pitch, addition or relocation of mechanical units, and change of roof material where the total weight exceeds 10 psf. (pounds per square foot)

**PERMITS NOT REQUIRED (Building or other)**  
(Common examples)

1. One-story detached accessory structures used as tool and storage sheds, tree-supported play structures, playhouses, and similar uses not exceeding 200 s.f. (Kirkland-vehicular use not allowed)
2. Fences not over 6' high (for Bellevue: fences not over 8' high).
3. Retaining walls or rockeries which are not over 4' in height measured from the bottom of the footing to the top of the wall unless located in a sensitive area, is supporting a surcharge or supporting sloped ground. (see page 2)
4. Sidewalks, decks, and driveways not more than 30" above grade and not over a basement or story below.
5. In-kind re-roofing provided roof sheathing is not removed or replaced.
6. Replacement of decking on docks and decks without replacement of any other structural members.
7. Painting, nonstructural siding (except veneer, stucco or EIFS), papering, tiling, carpeting, cabinets, countertops, and similar finish work.
8. Swings, slides, and other playground equipment.
9. In kind window replacement where no structural alteration is required. Window U-values must meet current WSEC prescriptive requirements.
10. Window awnings supported by an exterior wall which do not project more than 54" and do not require additional support.
11. Bathroom and kitchen fixture replacements without plumbing line modifications such as sinks and toilets.
12. Appliance replacement in the same location without modification to gas, plumbing lines, or electrical circuits such as dishwashers, ranges, ovens, gas logs, washers, and dryers.
13. Residential re-roof overlay if limited to 2 total layers of roofing material. (Note: Permit required in Bothell and Kenmore)

**GENERAL INFORMATION:**

- Consult with your local planning department regarding required setbacks.
- The intent of this sheet is to address the requirements of when a building permit is required. For residential projects, please contact your local building department regarding specific questions not addressed here or requiring further clarification.

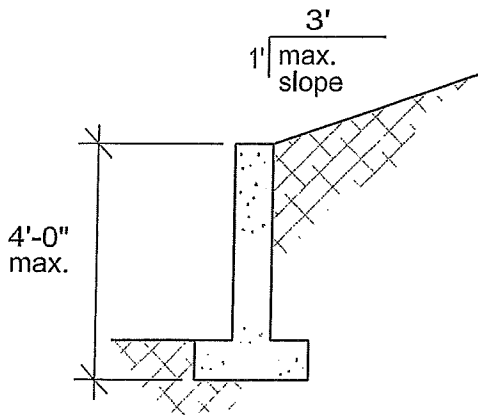

Low slope retaining wall:  
No permit required

**NOTE:**

Verify location of utilities and easements before starting the work.

Call before you dig.  
Phone: 1-800-424-5555

